

LECTURE 9

Soo-Won Kim
swkim@korea.ac.kr

10. Comparators

10.1 Comparator Specifications

10.2 Using an Opamp for a Comparator

10.3 Charge-Injection Errors



ADC block diagram

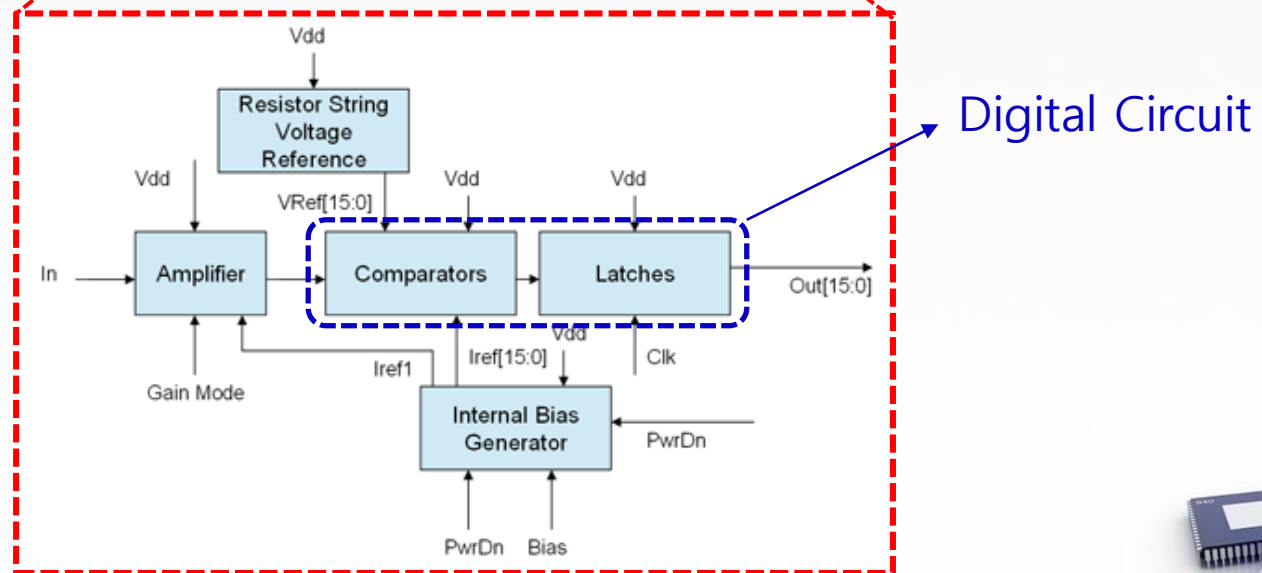
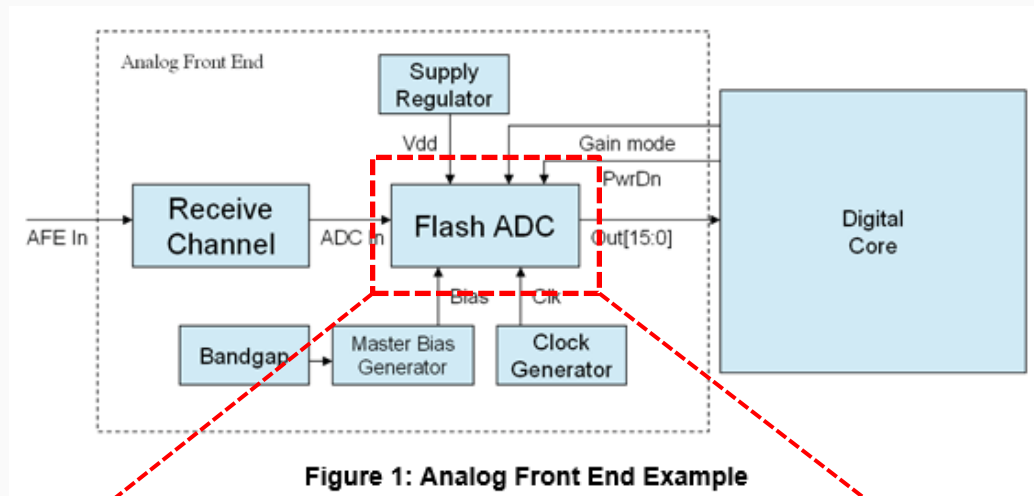

Open-loop opamp for a comparator

Simplistic approach

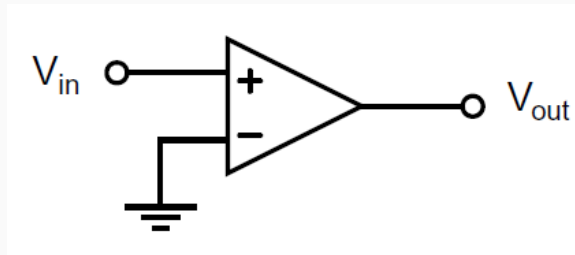

Fig. 10.2 A simplistic approach of using an open-loop opamp for a comparator

Operation

$$V_{in} > 0 \rightarrow V_{out} = V_{DD}$$
$$V_{in} < 0 \rightarrow V_{out} = 0$$

Compare the input with ground!!

😊 **Simple to implement**

😞 **Limited input-offset voltage**

What is offset?

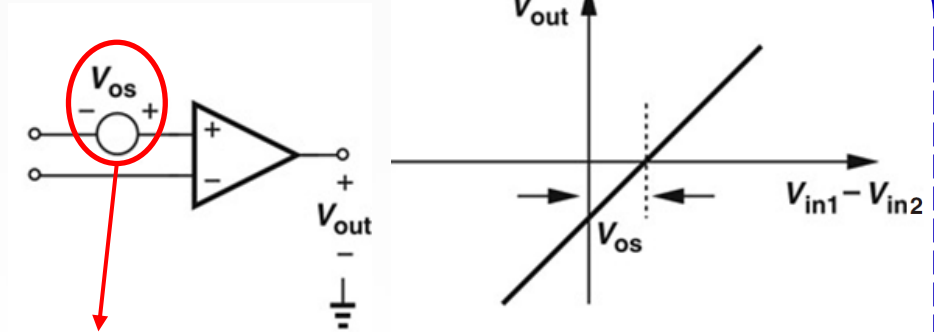

Cause of offset
: Device **Mismatches**

Recall *Analog CMOS I.C (Razavi) ch.13.2*

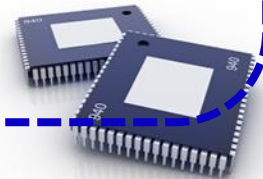

Input-Offset Voltage Errors

< Limited input-offset voltage >

Switched-capacitor comparators

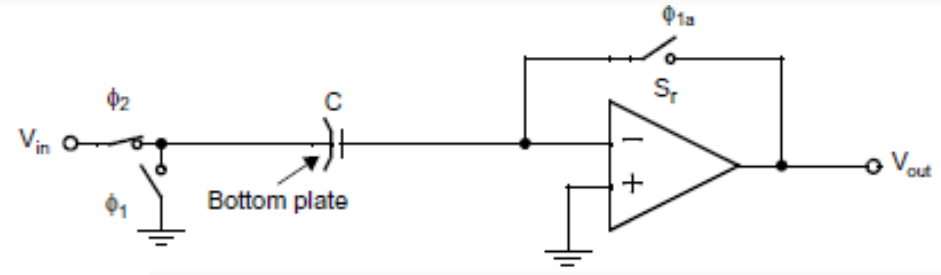
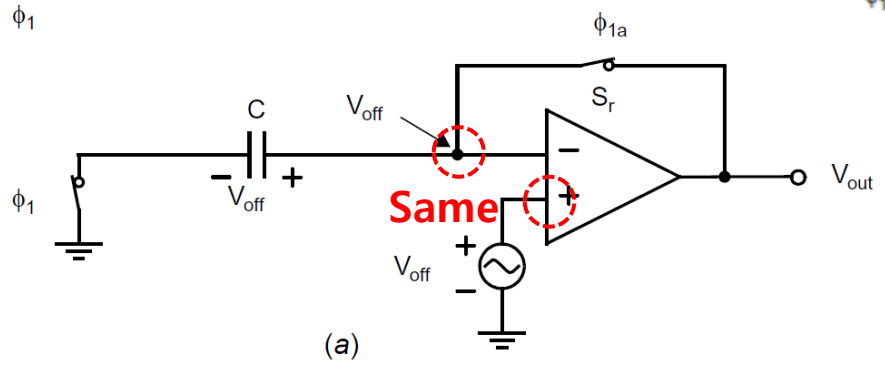

Fig. 10.3

During ϕ_1



(a)

During ϕ_2

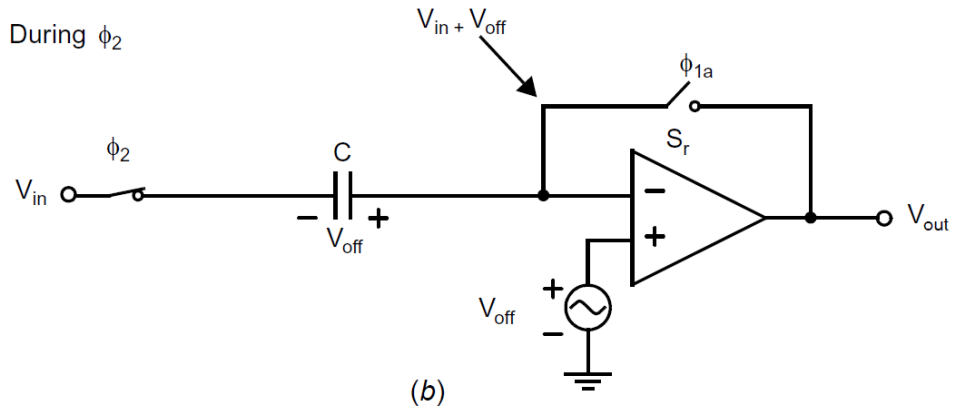

(b)

Fig. 10.6 The circuit configuration (a) during the reset phase, (b) during the comparison phase

- When ϕ_1 is closed and ϕ_{1a} is closed

$$V_{in+} = V_{in-} = V_{off}$$

- When ϕ_2 is closed and ϕ_{1a} is opened

$$V_{in+} = V_{off}$$

$$V_{in-} = V_{off} + V_{in}$$

Eliminate input-offset voltage!!



Switched-capacitor?

Switched-capacitor comparators

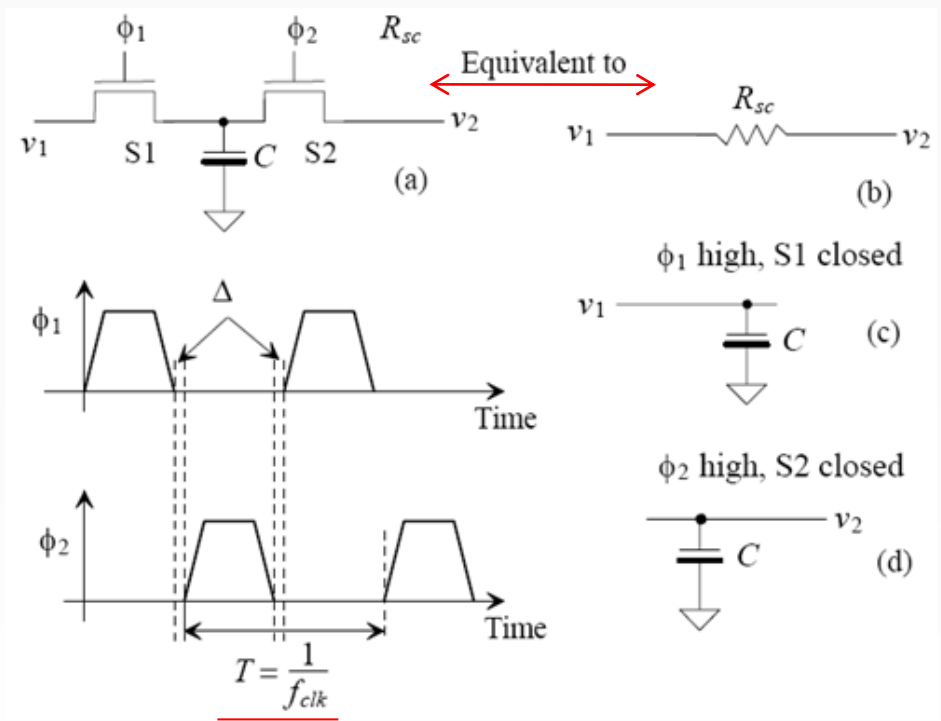

Switched-capacitor resistor (a) and associated waveforms and (b,c,d) the equivalent circuits

- When ϕ_1 is high and ϕ_2 is low
 $q_1 = Cv_1$
- When ϕ_2 is high and ϕ_1 is low
 $q_2 = Cv_2$
- If $v_1 \neq v_2$, charge equal to difference
 $q_1 - q_2 = C(v_1 - v_2)$

$$I_{avg} = \frac{C(v_1 - v_2)}{T} = \frac{v_1 - v_2}{R_{sc}}$$

$$R_{sc} = \frac{T}{C} = \frac{1}{C \cdot f_{clk}}$$



Time, S, Z - Domain

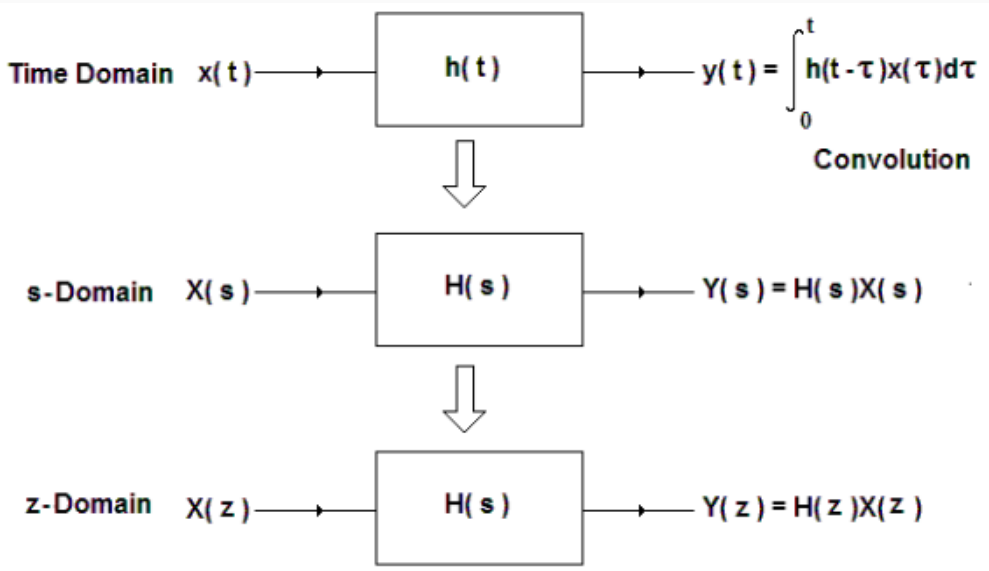
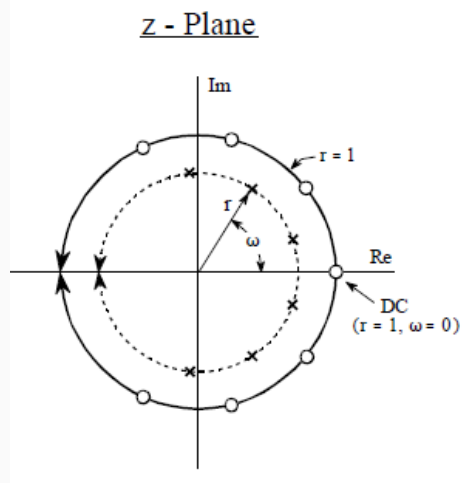
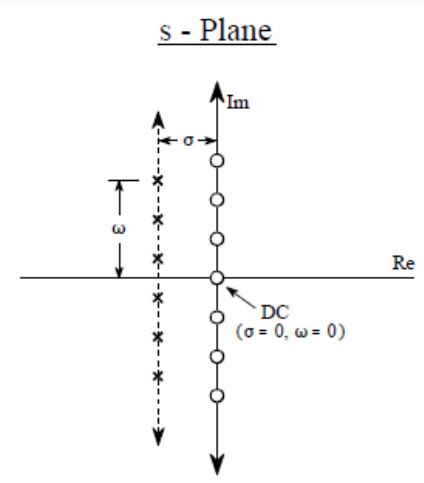
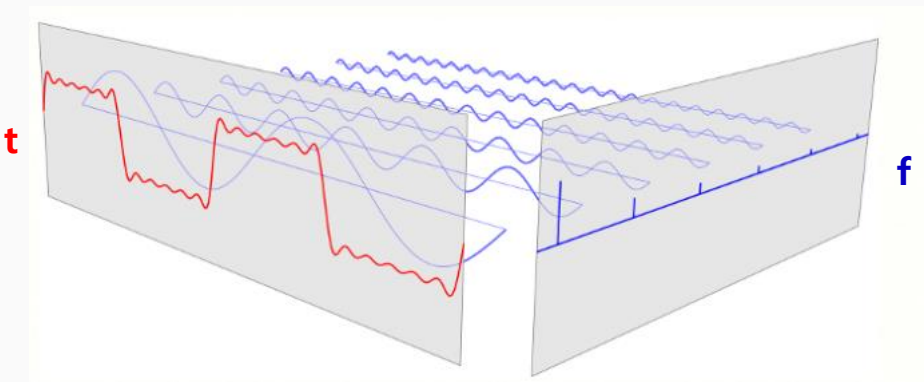

Reference

<http://www.faqsys.info/replicate-the-fourier-transform-time-frequency-domains-correspondence-illustration-using-tikz/>

http://www.analog.com/static/imported-files/tech_docs/dsp_book_Ch33.pdf



Charge-Injection Errors

Charge Injection

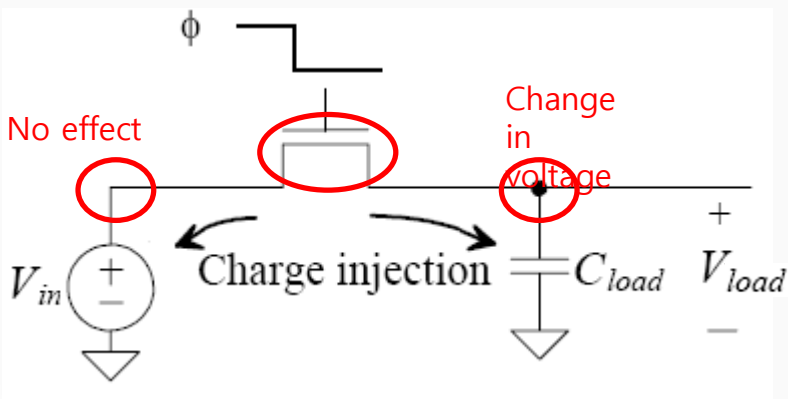

$$Q_I(y) = C'_{ox} \times W \times L \times (V_{GS} - V_{THN})$$

$$\Delta V_{load} = - \frac{C'_{ox} \times W \times L \times (V_{GS} - V_{THN})}{2C_{load}}$$

$$\Delta V_{load} = - \frac{C'_{ox} \times W \times L \times (V_{DD} - V_{in} - V_{THN})}{2C_{load}} \quad (10.3)$$

Small-signal on-resistance of MOSFET switches

$$\Delta V_{load} = - \frac{C'_{ox} \times W \times L \times \left(V_{DD} - V_{in} - \left[V_{THN0} + \gamma \left(\sqrt{|2V_{fp} - V_{in}|} - \sqrt{|2V_{fp}|} \right) \right] \right)}{2C_{load}}$$

➔ V_{LOAD} is **nonlinear** with respect to V_{in} due to **threshold voltage**



Minimizing Error Due to Charge-Injection

Capacitive Feedthrough

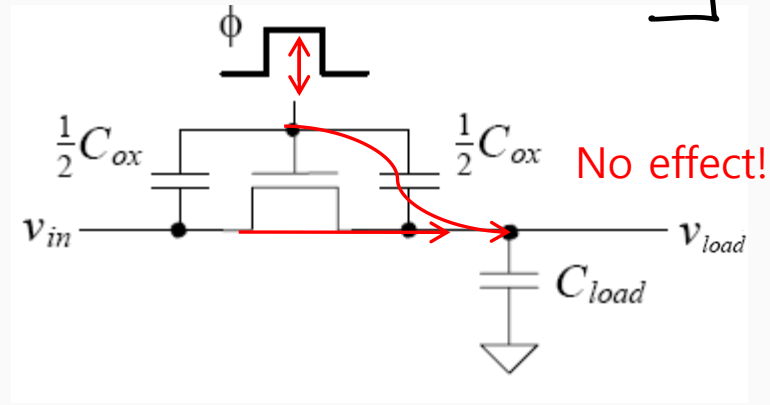

Illustration of capacitive feedthrough



$$C_{overlap} = C'_{ox} \cdot W \cdot \underline{LD}$$

Length of the gate that overlaps the drain/source

$$\Delta v_{load} = \frac{C_{overlap} \cdot VDD}{C_{overlap} + C_{load}} \quad (10.8)$$

Reduction of Charge Injection and Clock Feedthrough

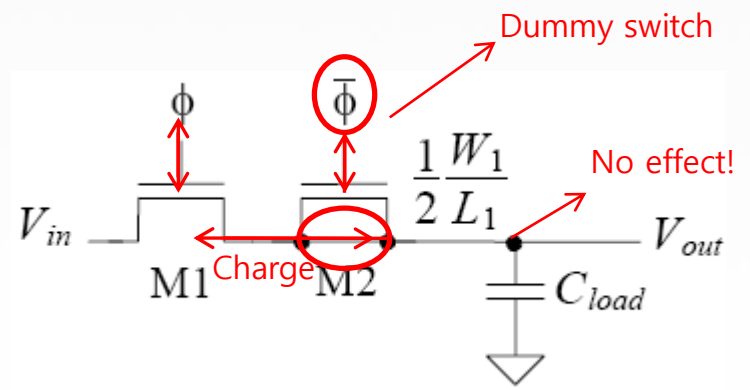

Dummy switch circuit used to minimize charge injection

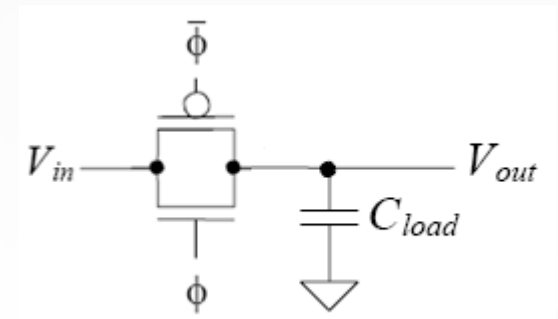

Another method for counteracting charge injection and clock feedthrough

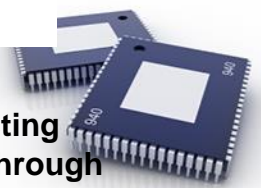

Charge-Injection & Clock Feedthrough

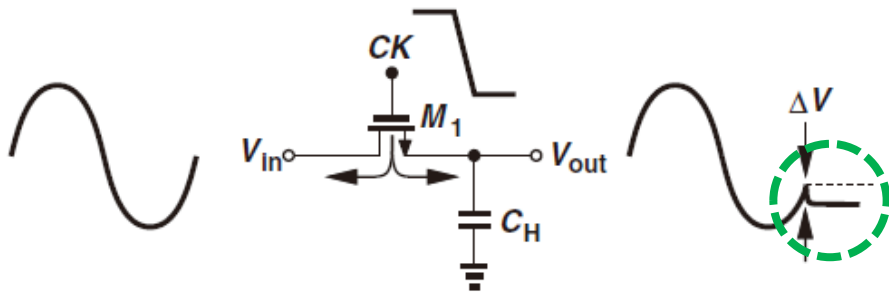

Charge injection

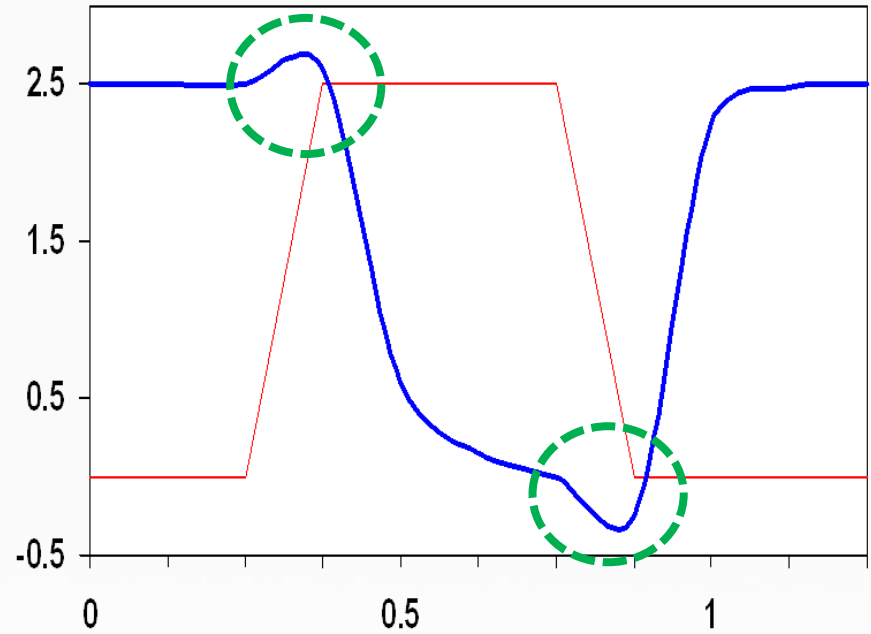

Clock Feedthrough



Minimizing Charge-Injection Error

Reduction of Charge Injection using differential pair

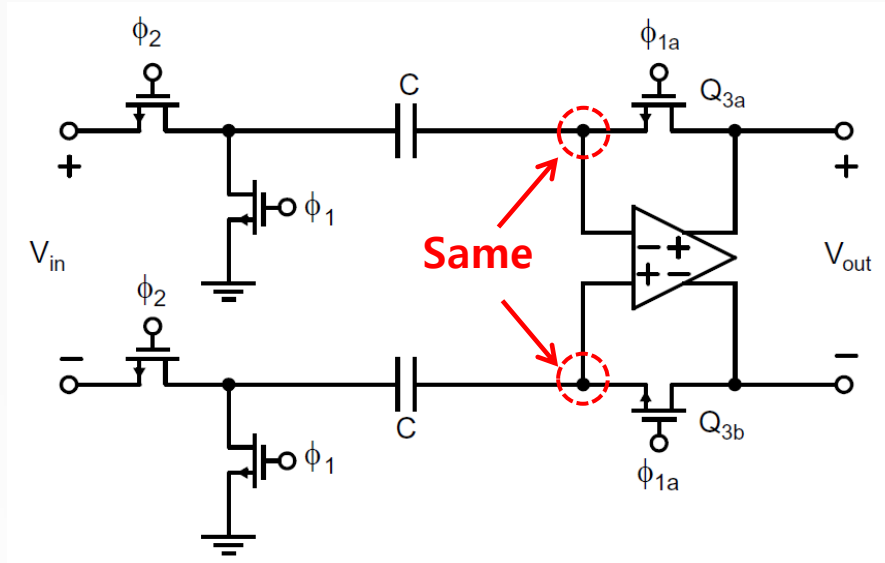
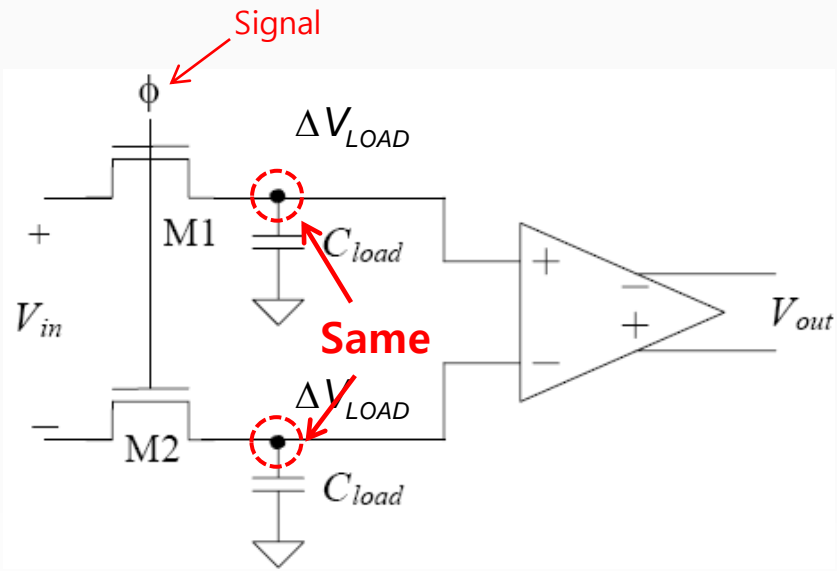

Using a fully-differential circuit to minimize charge injection and clock feedthrough

Fig. 10.10 A Fully differential, single-stage, switched-capacitor comparator



Example 1

Parameter values

$$C_H = 1\text{pF}, C_{ox} = 6.9\text{fF}/(\mu\text{m})^2, (W/L)_1 = 20/0.5,$$

$$C_{ov} = 400\text{pF}, V_{TH} = 0.7\text{V}, V_{DD} = 3\text{V}$$

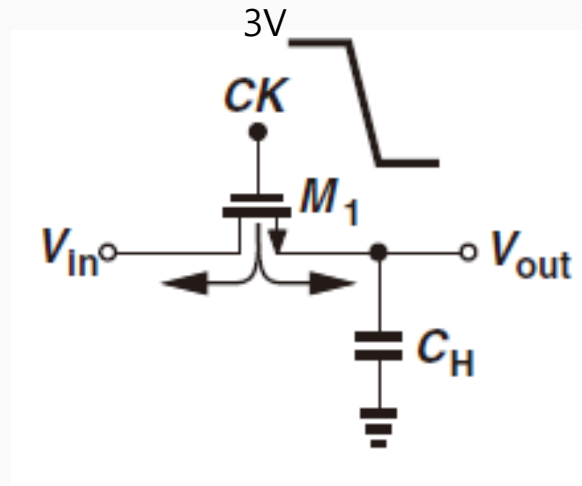

Charge injection

$$\Delta V = -\frac{(V_{DD} - V_{TH})C_{ox}W_3L_3}{2C} = -\frac{(3 - 0.7) \times \left(\frac{6.9 \times 10^{-15}}{10^{-12}} \right) \times 10 \times 10^{-6} \times 0.9 \times 10^{-6}}{2 \times 1 \times 10^{-12}}$$

$$= -71.415\text{mV}$$

Clock feedthrough

$$C_{ov} = 400\text{p} \cdot 20\mu = 8\text{fF}$$

$$\Delta V'' = -V_{CK} \cdot \frac{C_{ov}}{C_{ov} + C_H} \approx -V_{CK} \cdot \frac{C_{ov}}{C_H} = \frac{8\text{f}}{1\text{p}} \cdot 3\text{V} = -24\text{mV}$$



Example 2

Parameter values

$$C = 2\text{pF}, C_{ox} = 2.1\text{fF}/(\mu\text{m})^2, (W/L)_3 = 10\mu\text{m}/0.9\mu\text{m},$$

$$L_{OV} = 0.1\mu\text{m}, V_{TH} = 0.8\text{V}, V_{DD} = 2.6\text{V}, V_{SS} = -2.6\text{V}$$

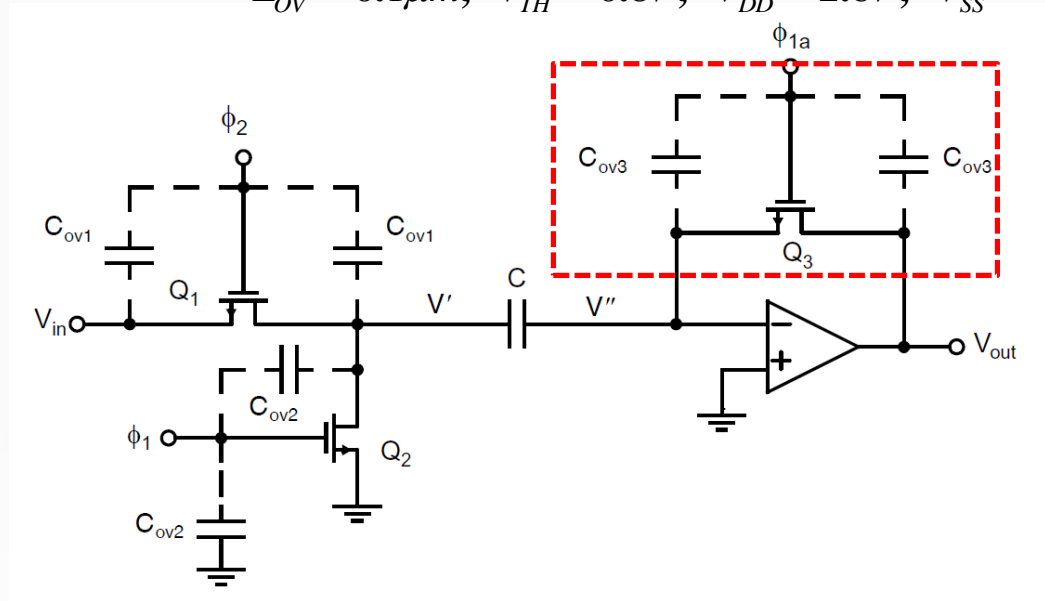

Fig. 10.7 The comparator in Fig. 10.3, with n-channel switches and overlap capacitance shown.

$$\Delta V'' = \frac{(Q_{ch}/2)}{C} \quad (10.3)$$

a. Calculate the voltage change **due to channel charge**

$$\Delta V'' = -\frac{(V_{DD} - V_{TH})C_{ox}W_3L_3}{2C} = -\frac{(2.6 - 0.8) \times (2.1 \times 10^{-3}) \times 10 \times 10^{-6} \times 0.9 \times 10^{-6}}{2 \times 2 \times 10^{-12}}$$

$$= -8.505\text{mV}$$



Example 2(Cont.)

Parameter values

$$C = 2\text{pF}, C_{ox} = 2.1\text{fF}/(\mu\text{m})^2, (W/L)_3 = 10\mu\text{m}/0.9\mu\text{m}, \\ L_{ov} = 0.1\mu\text{m}, V_{TH} = 0.8\text{V}, V_{DD} = 2.6\text{V}, V_{SS} = -2.6\text{V}$$

b. Calculate the voltage change due to overlap capacitance

Overlap capacitance is given by

$$C_{ov} = W_3 L_{ov} C_{ox} = 10 \times 10^{-6} \times 0.1 \times 10^{-6} (2.1 \times 10^{-3}) = 2.1\text{fF}$$

Voltage change due to overlap capacitance

$$\Delta V'' = -\frac{(V_{DD} - V_{SS})C_{ov}}{C_{ov} + C} = -\frac{(2.6 + 2.6) \times 2.1 \times 10^{-15}}{2.1 \times 10^{-15} + 2.1 \times 10^{-12}} = -5.454\text{mV}$$

$$\Delta V_{load} = \frac{C_{overlap} \cdot V_{DD}}{C_{overlap} + C_{load}} \quad (10.8)$$

c. Calculate the total voltage change due to both

$$\Delta V' = -(8.505 + 5.454)\text{mV} = -13.959\text{mV}$$

